

TOP-RUNNING ROTATING AXLE END TRUCKS



GWBI Top-Running Rotating Axle End Trucks - *Standard Features*

Designed up through CMAA Class 'E' Service

The GWBI Top-Running Rotating Axle End Trucks are available in a wide range of capacities and configurations for single girder, double girder and 8 wheel bogie. Designed for crane builders and end users that value heavier & rugged crane components.

Full customer service staff to handle support.



Rotating Axle End Trucks

Designed in accordance with the latest CMAA specifications and are of heavy wall, steel tube construction for maximum stiffness. Array of wheel bases for a large range of bridge spans available.

End Truck Wheel Assemblies

Alloy steel double flanged wheels with straight tread at a hardness of 400 BHN are mounted on rotating axles supported by spherical roller bearings in steel bearing caps. Will operate on ASCE rail or square bar.

Drives

A-4 type drives with hollow shaft mounted gear motors and DC disc brakes. Motors are continuous inverter duty with class 'F' insulation, TEFC as standard.

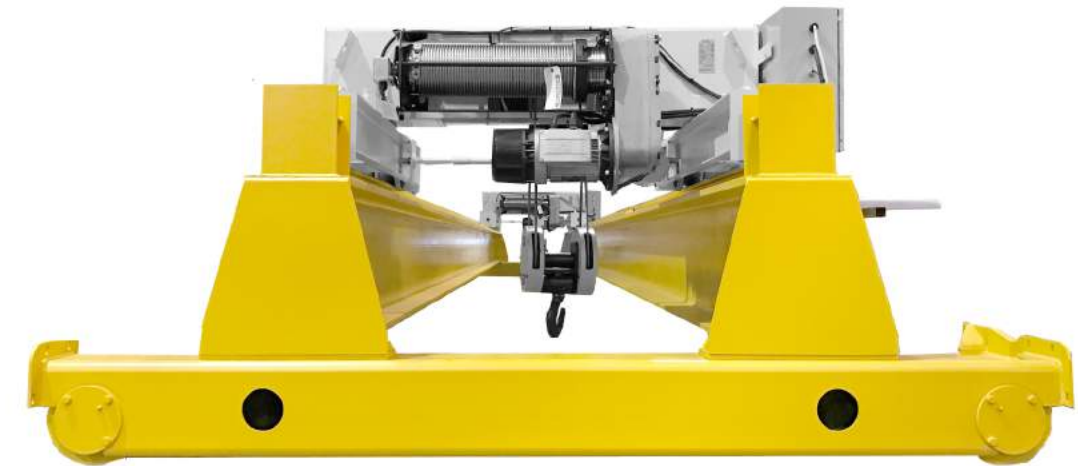

GWBI Rotating Axle End Trucks are designed for ease of maintenance and installation.

3 Wheel Sizes Available

9", 12", and 15" wheel sizes covering a wide range of capacities and applications.

Driver & Idler Wheel Type - Rotating Axle

No exposed gearing. Bearings are individually lubricated through grease fittings.

Bolted Connections

Designed for ease of installation, end truck has bolted top or top & side connection plates with access hole for tightening bolts.

Bolted Rail Sweep

Designed for ease of removal to access wheel. Energy absorbing bumpers mounted on sweep. Bumpers will be sized per CMAA specifications.

Bogie Truck Configuration

Designed for double girder with connection pin and bar. Allows for easy installation and reduces shipping costs for larger cranes.

Crane Kits Available

Options

- Custom end truck wheelbases
- Outdoor service
- Polyurethane wheels
- Equalizing double girder bogie design
- Controls
- Hydraulic bumpers
- Wheels up to 600 BHN hardness

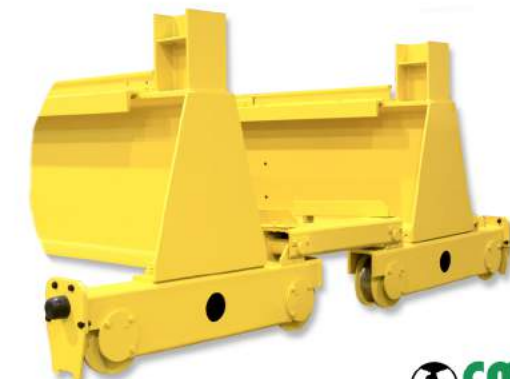

Tube end trucks shown in double girder bogie design configuration.

Specifications:

- CMAA Class 'D' & 'E' Service
- Gear motors for use with variable frequency controls
- Speeds of 100, 150, 200 fpm
- The frame of the GWBI End Truck is made from A-500 Grade B structural steel tubing
- Hand holes are provided for girder installation
- All wheels are straight tread geometry and are 400 BHN
- 2 wheel tread ranges, 20-40# rail and 60-105# rail, not for use on 100# rail
- Each GWBI End Truck is equipped with four (4) spherical roller bearings (2) per wheel
- Each bearing will be greased through a bearing housing mounted grease fitting
- Minimum jacking lift height is required to replace wheels or bearings
- Energy absorbing bumpers per CMAA specifications
- Standard is for indoor service



G.W. Becker, Inc. - Crane Components

GWBI Heavy Duty Steel Plate Fabricated Rotating Axle End Trucks

Designed in accordance with the latest CMAA specifications; welded steel, heavy service, box construction for maximum stiffness, wheel base for appropriate bridge span, two (2) wheels and equipped with rail sweeps. Available in bogie configurations. AP bearings optional.

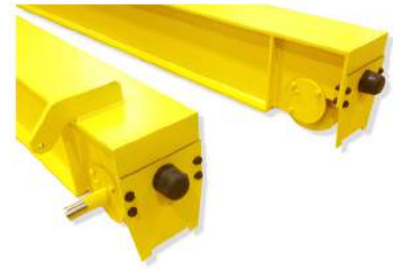

GWBI Top-Running Wire Rope Hoist

Designed for CMAA Class 'D' & 'E' service, with capacities up to 75 tons.

Our top-running wire rope hoist is a precision built-up style hoist in a pre-engineered package unit. Designed for crane builders and end-users that value a heavier & rugged unit. Customizable in gauge, lift, and speed.



The leading feature is our powerful gear case which is designed and manufactured to provide the performance and reliability your lifting applications demand. This is not your typical "off-the-shelf" unit.

Engineered with standardized componentry, our GWBI hoist provides lower cost of ownership and ease of replacement for wear items.

GWBI Crane Kits

Designed for CMAA Class 'D' & 'E' service, with capacities up to 75 tons and spans up to 150 ft.

The GWBI crane kits are precision built-up style components in a pre-engineered package platform. Designed for crane builders and end users that value a heavier & rugged unit. Customizable in gauge, lift, speed and span.



Engineered with standardized componentry, our GWBI crane kits provides lower cost of ownership and ease of replacement for wear items.



Production Facility
2600 Kirila Blvd., Hermitage, PA



Sales and Service Facility
1565 Broadway Rd., Hermitage, PA